

*This product utilizes R-32 refrigerant*

# MRCOOL® Compact Refrigeration System

## SERVICE MANUAL

**MODELS:**  
MMFDW12D



Read this manual carefully before installation and keep it where the operator can easily find it for future reference.

Due to updates and constantly improving performance, the information and instructions within this manual are subject to change without notice.

Version Date: February 9, 2025  
Please visit [www.mrcool.com/documentation](http://www.mrcool.com/documentation)  
to ensure you have the latest version of this manual.



## CONTENTS

<b>1 SAFETY</b> .....	1
<b>2 NOMENCLATURE</b> .....	8
<b>3 GENERAL DATA</b> .....	9
<b>4 TROUBLESHOOTING</b> .....	10
4.1 Error Codes .....	10
4.2 Uncoded Errors .....	20
<b>5 MAINTENANCE</b> .....	23
5.1 Evaporator Fan .....	23
5.2 Condenser Fan .....	26
5.3 Temperature Sensors .....	29

## Safety Precautions

### Read Before Using

Incorrect usage may cause serious damage or injury.

The symbols below are used throughout this manual to indicate instructions that should be followed closely or actions that should be avoided to prevent death, injury, and/or property damage.



Indicates the possibility of personal injury or loss of life.



Indicates the possibility of property damage or serious consequences.

## REFRIGERANT

- The air conditioning unit operates using a circulating refrigerant. The system utilizes R32, a fluorinated refrigerant. R32 is mildly flammable and odorless. Although it can form explosive mixtures with air under specific conditions, its flammability is low and requires a direct ignition source.
- Compared to common refrigerants, R32 has an ozone depletion potential (ODP) of zero and a lower global warming potential (GWP). Its superior thermodynamic properties enable higher energy efficiency, allowing systems to operate with a lower refrigerant charge.



A2L

## ! PRECAUTIONS

- Only use manufacturer-recommended methods for defrosting and cleaning. Do not use any other tools or devices.
- Store the appliance in a room that is free of active ignition sources, such as open flames, functioning gas appliances, or operating electric heaters.
- Never puncture or incinerate any part of the refrigeration system.
- Warning: Refrigerant is odorless. You will not be able to smell a leak.

## ! WARNING

1. Before touching electrical parts, turn off all applicable power to the unit.
2. When service panels are removed, live parts can be easily touched by accident.
3. Never leave the unit unattended during installation or servicing when the service panel is removed.
4. Do not touch pipes during and immediately after operation as the pipes may be hot and could burn your hands. To avoid injury, give the piping time to return to normal temperature or be sure to wear protective gloves.
  - a. Do not touch any switch with wet fingers. Touching a switch with wet fingers can cause electrical shock.
  - b. Piping material, pipe routing, and installation shall include protection from physical damage in operation and service, and be in compliance with national and local codes and standards, such as ASHRAE 15, ASHRAE 15.2, IAPMO Uniform Mechanical Code, ICC International Mechanical Code, or CSA B52. All field joints shall be accessible for inspection prior to being covered or enclosed.
5. For appliances containing FLAMMABLE REFRIGERANTS, the minimum floor area of the room shall be mentioned on PAGE 7.
6. When installing or relocating the unit, be sure to keep the refrigerant circuit free from air or substances other than the specified refrigerant.
7. Any presence of air or other foreign substance in the refrigerant circuit will cause system pressure rise or compressor rupture, resulting in injury.
8. When installing or moving this unit, do not charge the refrigerant which is not comply with that on the nameplate or unqualified refrigerant. Otherwise, it may cause abnormal operation, wrong action, mechanical malfunction or even series safety accident.
9. When refrigerant needs to be recovered during relocating or repairing the unit, be sure that the unit is running in cooling mode. Then, fully close the valve at high pressure side (liquid valve). About 30-40 seconds later, fully close the valve at low pressure side (gas valve), immediately stop the unit and disconnect power. Please note that the time for refrigerant recovery should not exceed 1 minute. If refrigerant recovery takes too much time, air may be sucked in and cause pressure rise or compressor rupture, resulting in injury.
10. During refrigerant recovery, make sure that liquid valve and gas valve are fully closed and power is disconnected before detaching the connection pipe.



## WARNING, CONTD.

11. If compressor starts running when stop valve is open and connection pipe is not yet connected, air will be sucked in and cause pressure rise or compressor rupture, resulting in injury.
12. When installing the unit, make sure that connection pipe is securely connected before the compressor starts running.
13. If compressor starts running when stop valve is open and connection pipe is not yet connected, air will be sucked in and cause pressure rise or compressor rupture, resulting in injury.
14. Prohibit installing the unit at the place where there may be leaked corrosive gas or flammable gas. If there leaked gas around the unit, it may cause explosion and other accidents.
15. Do not use extension cords for electrical connections. If the electric wire is not long enough, please contact a local service center authorized and ask for a proper electric wire. Poor connections may lead to electric shock or fire.
16. Use the specified types of wires for electrical connections between the indoor and outdoor units. Firmly clamp the wires so that their terminals receive no external stresses.
17. Electric wires with insufficient capacity, wrong wire connections and insecure wire terminals may cause electric shock or fire.
18. Ground the unit.
19. Grounding resistance should be according to local laws and regulations.
20. Do not connect the ground wire to gas or liquid pipes, lightning conductors or telephone ground wires.
21. Incomplete grounding may cause electric shocks.
  - a. Gas pipes: Fire or an explosion might occur if the gas leaks.
  - b. Lightning conductors or telephone ground wires: Electrical threshold may rise abnormally if struck by a lightning bolt.
22. Install the power wire at least 3 feet (1 meter) away from televisions or radios to prevent interference or noise. (Depending on the radio waves, a distance of 3 feet (1 meter) may not be sufficient to eliminate the noise.)
23. Do not wash the live parts of the unit. This may cause electric shocks or fire. The appliance must be installed in accordance with national wiring regulations. If the supply cord is damaged, it must be replaced by the manufacturer, its service agent or similarly qualified persons in order to avoid a hazard.
24. Do not install the unit in the following places:
  - a. Where there is a mineral oil mist, oil spray, or vapors. Plastic parts may deteriorate, and cause them to come loose to leak.
  - b. Where corrosive gases (such as sulphuric acid gas) are produced. Where corrosion of copper pipes or soldered parts may cause refrigerant to leak.
  - c. Where there is machinery which emits electromagnetic waves. Electromagnetic waves can disturb the control system and cause equipment malfunction.
  - d. Where flammable gases may leak, where carbon fiber or ignitable dust is suspended in the air or where volatile flammable such as paint thinner or gasoline are handled. These types of gases might cause a fire.
  - e. Where the air contains high levels of salt such as near the ocean.
  - f. Where voltage fluctuates a lot, such as in factories.
  - g. In vehicles or vessels.
  - h. Where acidic or alkaline vapors are present.
25. If the supply cord is damaged, it must be replaced by the manufacturer or its service agent or a similarly qualified person.
26. DISPOSAL: Do not dispose this product as unsorted municipal waste. Collection of such waste separately for special treatment is necessary. Do not dispose of electrical appliances as municipal waste, use separate collection facilities. Contact your local government for information regarding the collection systems available. If electrical appliances are disposed of in landfills or dumps, hazardous substance can leak into the ground water and get into the food chain, damaging your health and well-being.
27. The wiring must be performed by professional technicians in accordance with national wiring regulation and this circuit diagram. An all-pole disconnection device which has at least 3mm separation distance in all pole and a residual current device (RCD) with the rating not exceeding 30mA shall be incorporated in the fixed wiring according to the national rule. Before wiring/pipes, confirm the safety of the installation area (walls, floors, etc.) without hidden dangers such as water, electricity, and gas.



## WARNINGS, CONTD.

28. Before installation, check whether the user's power supply meets the electrical installation requirements of unit (including reliable grounding, leakage, and wire diameter electrical load, etc.). If the electrical installation requirements of the product are not met, the installation of the product is prohibited until the product is rectified.
29. When installing multiple units in a centralized manner, please confirm the load balance of the power supply, and multiple units are prevented from being assembled into the same phase of the power supply.
30. Product installation should be fixed firmly. Take reinforcement measures, when necessary.
31. To repair or dispose of the equipment, contact the after-sales service team. The equipment uses refrigerant R32, and it must be repaired by professionals.
32. Transport of equipment containing flammable refrigerants: See transport regulations.
33. Marking of equipment using signs: See local regulations.
34. Disposal of equipment using flammable refrigerants: See national regulations.
35. Storage of equipment/appliances: The storage of equipment should be in accordance with the MRCOOL® instructions.
36. Storage of packed (unsold) equipment: Storage package protection should be constructed such that mechanical damage to the equipment inside the package will not cause a leak of the refrigerant charge.
37. The maximum number of pieces of equipment permitted to be stored together will be determined by local regulations.
38. To realize the function of the product, a special refrigerant circulates in the system. The used refrigerant is R32, which is highly flammable.
39. The refrigerant is flammable and in-odorous. Furthermore, it can lead to explosion under certain conditions. But the flammability of the refrigerant is very low. It can be ignited only by fire.
40. Compared to common refrigerants, R32 is a nonpolluting refrigerant with no harm to the ozonosphere. The influence upon the Green house effect is also lower. R32 has got very good thermodynamic features which lead to a really high energy efficiency. The units therefore need less filling.
41. Qualification of Service Personnel: Any person who is involved with working on or repairing refrigerating circuits should possess a valid certificate issued by industry recognized assessment organizations certifying that they have the necessary qualifications required for handling refrigerants safely. Only maintain and repair the product following the methods recommended by the manufacturer. If other technicians are required for assistance, the maintenance or repair should be supervised by persons qualified for handling R32 refrigerants.
42. Checks to the Area: Prior to beginning work on the product that uses refrigerant R32, safety checks are necessary to ensure that the risk of ignition is minimized. For repair to the refrigerating system, the following precautions shall be complied with before conducting work on the system.
43. Work procedure: Work shall be undertaken under a controlled procedure to minimize the risk of flammable gas or vapor being present while the work is being performed.
44. General work area: All maintenance staff and others working in the local area shall be instructed on the nature of work being carried out. Work in confined spaces shall be avoided.
45. Check for the presence of refrigerant: The area shall be checked with an appropriate refrigerant detector prior to and during work, to ensure the technician is aware of potentially flammable atmospheres. Ensure that the leak detection equipment being used is suitable for use with flammable refrigerants, i.e. non-sparking, adequately sealed, or intrinsically safe.
46. Presence of fire extinguisher: If any hot work is to be conducted on the refrigerating equipment or any associated parts, appropriate fire extinguishing equipment shall be available to hand. Have a dry powder or CO2 fire extinguisher adjacent to the charging area.
47. No ignition sources: No person carrying out work in relation to a refrigerating system that involves exposing any pipe work that contains or has previously contained flammable refrigerants shall use any sources of ignition in such a manner that it can lead to the risk of fire or explosion. All possible ignition sources, including cigarette smoking, should be kept sufficiently far away from the site of installation, repair, removal, and disposal, during which refrigerant can be released into the surrounding space. Prior to work taking place, the area around the equipment is to be surveyed to make sure that there are no flammable hazards or ignition risks. "No Smoking" signs shall be displayed.



## WARNINGS, CONTD.

48. Ventilated Area: Ensure that the area is in the open or that it is adequately ventilated before breaking into the system or conducting any hot work. A degree of ventilation shall continue during the period that the work is carried out. The ventilation should safely disperse any released refrigerant and preferably expel it externally into the atmosphere.
49. Checks to the Refrigerating Equipment: Where electrical components are being changed, they shall be fit for the purpose and to the correct specification. At all times the manufacturer's maintenance and service guidelines shall be followed. If in doubt, consult the manufacturer's technical department for assistance. The following checks shall be applied to installations of products using R32 refrigerants:
  - a. The refrigerant charge is in accordance with the room size within which the refrigerant-containing parts are installed.
  - b. The ventilation machinery and outlets are operating adequately and are not obstructed.
  - c. If an indirect refrigerating circuit is being used, the secondary circuit shall be checked for the presence of refrigerant.
  - d. Marking to the product continues to be visible and legible. Markings and signs that are illegible shall be corrected.
  - e. Refrigerating pipe or electrical components are installed in a position where they are unlikely to be exposed to any substance that can corrode refrigerant-containing components, unless the electrical components are constructed of materials that are inherently resistant to being corroded or are suitably protected against being so corroded.
50. Checks to Electrical Devices: Repair and maintenance of electrical components shall include initial safety checks and component inspection procedures. If a fault exists that could compromise safety, then no electrical supply shall be connected to the circuit until it is satisfactorily dealt with. If the fault cannot be corrected completely in the end, but it is necessary to continue operation, an adequate temporary solution shall be used. This shall be reported to the owner of the equipment so all parties are advised.
51. Initial safety checks shall include: That capacitors are discharged: this shall be done in a safe manner to avoid the possibility of sparking. That no live electrical components and accessories are exposed while charging, recovering, or purging the system. That there is continuity of earth bonding.
52. Repairs to Sealed Components: Sealed electrical components shall be replaced.
53. Repairs to Intrinsically Safe Components: Intrinsically safe components must be replaced.
54. Cabling: Check that cabling will not be subject to wear, corrosion, excessive pressure, vibration, sharp edges, or any other adverse environmental effects. The check shall also take into account the effects of aging or continual vibration from sources such as compressors or fans.
55. Detection of Refrigerant R32: After entering the cooling or heating command for the air conditioner, if the air blown out by the unit is neither cold nor hot, please first open the windows for ventilation or turn on the exhaust fan. Then check whether the machine has any faults. If there is a refrigerant leakage fault or a refrigerant shortage fault, please contact service personnel for on-site repair. Before the repair is completed, please keep the area ventilated.
56. Under no circumstances shall potential sources of ignition be used in the search for or detection of refrigerant leaks. A halide torch (or any other detector using a naked flame) shall not be used.
57. Leak Detection Methods: LEAK DETECTION SYSTEM installed. Unit must be powered except for service. The following leak detection methods are deemed acceptable for systems containing refrigerant R32:
  - a. Electronic leak detectors may be used to detect refrigerant R32, but the sensitivity may be inadequate or may need re-calibration (Detection equipment shall be calibrated in a refrigerant-free area). Ensure that the detector is not a potential source of ignition and is suitable for the refrigerant used. Leak detection equipment shall be set at a percentage of the lower flammability limit (LFL) of the refrigerant and shall be calibrated to the refrigerant employed, and the appropriate percentage of gas (25% maximum) is confirmed.
  - b. Leak detection fluids shall be suitable for use with most refrigerants but the use of solvents containing chlorine shall be avoided as the chlorine can react with the refrigerant and corrode the copper pipe-work.
  - c. If a leak is suspected, all naked flames shall be removed or extinguished.
  - d. If a leakage of refrigerant is found which requires brazing, all of the refrigerant shall be recovered from the system, or isolated by means of shut-off valves in a part of the system remote from the leak. Before and during brazing, purge the entire system with oxygen-free nitrogen (OFN).









## WARNINGS, CONTD.

58. Removal and Evacuation: When breaking into the refrigerant circuit to make repairs - or for any other purpose - conventional procedures shall be used. However, for flammable refrigerants it is important that best practice be followed, since flammability is a consideration. The following procedure shall be adhered to:
- Safely remove refrigerant following local and national regulation
  - Evacuate
  - Purge the circuit with inert gas (optional for A2L)
  - Evacuate (optional for A2L)
  - Continuously flush or purge with inert gas when using flame to open circuit
  - And open the circuit
59. The refrigerant charge shall be recovered into the correct recovery cylinders if venting is not allowed by local and national codes. For appliances containing flammable refrigerants, the system shall be purged with oxygen-free nitrogen to render the appliance safe for flammable refrigerants. This process might need to be repeated several times. Compressed air or oxygen shall not be used for purging refrigerant systems.
60. For appliances containing flammable refrigerants, purging shall be achieved by breaking the vacuum in the system with oxygen-free nitrogen and continuing to fill until the working pressure is achieved, then venting to atmosphere, and finally pulling down to a vacuum (optional for A2L). This process shall be repeated until no refrigerant is within the system (optional for A2L). When the final oxygen-free nitrogen charge is used, the system shall be vented down to atmospheric pressure to enable work to take place.
61. The outlet for the vacuum pump shall not be close to any potential ignition sources, and ventilation shall be available.
62. Refrigerant Charging Procedures: In addition to conventional charging procedures, the following requirements shall be followed:
- Ensure that contamination of different refrigerants does not occur when using charging equipment. Hoses or lines shall be as short as possible to minimize the amount of refrigerant contained in them.
  - Cylinders shall be kept upright.
  - Ensure that the refrigerating system is earthed before charging the system with refrigerant.
  - Label the system after or before the completion of charging.
  - Extreme care shall be taken not to overfill the refrigerating system.
63. Prior to recharging the system, it shall be pressure-tested with oxygen-free nitrogen. The system shall be leak-tested on completion of charging but prior to commissioning. A follow-up leak test shall be carried out prior to leaving the site.
64. Decommissioning: Before carrying out this procedure, it is essential that the technician is completely familiar with the equipment and all its details. It is recommended good practice that all refrigerants are recovered safely. Prior to the task being carried out, an oil and refrigerant sample shall be taken in case analysis is required prior to re-use of recovered refrigerant. It is essential that electrical power is available before the task is commenced.
65. Become familiar with the equipment and its operation.
66. Isolate system electrically.
67. Before attempting the procedure, ensure that:
- Mechanical handling equipment is available, if required, for handling refrigerant cylinders
  - All personal protective equipment is available and being used correctly
  - The recovery process is supervised at all times by a competent person
  - Recovery equipment and cylinders conform to the appropriate standards
68. Pump down the refrigerant system, if possible.
69. If a vacuum is not possible, make a manifold so that refrigerant can be removed from various parts of the system.
70. Make sure that the cylinder has sufficient capacity before recovery takes place.
71. Start the recovery machine and operate in accordance with instructions.
72. Do not overfill cylinders (no more than 80% volume liquid charge).
73. Do not exceed the maximum working pressure of the cylinder, even temporarily.
74. When the cylinders have been filled correctly and the process completed, make sure that the cylinders and the equipment are removed from the site promptly and all isolation valves on the equipment are closed off.

## WARNINGS, CONTD.

75. Recovered refrigerant shall not be charged into another refrigerating system unless it has been cleaned and checked.
76. Labeling: Equipment shall be labeled stating that it has been decommissioned and emptied of refrigerant. The label shall be dated and signed. Ensure that there are labels on the equipment stating the equipment contains refrigerant R32.
77. Recovery: When removing refrigerant from a system, either for servicing or decommissioning, it is required to follow good practice so that all refrigerants are removed safely.
- When transferring refrigerant into cylinders, ensure that only appropriate refrigerant recovery cylinders are employed. Ensure that the correct number of cylinders for holding the total system charge is available. All cylinders to be used are designated for the recovered refrigerant and labeled for that refrigerant (i.e. special cylinders for the recovery of refrigerant). Cylinders shall be complete with pressure-relief valves and associated shut-off valves in good working order. Empty recovery cylinders are evacuated and, if possible, cooled before recovery occurs.
  - The recovery equipment shall be in good working order with a set of instructions concerning the equipment that is at hand and shall be suitable for the recovery of flammable refrigerants.
  - In addition, a set of calibrated weighing scales shall be available and in good working order. Hoses shall be complete with leak-free disconnect couplings and in good condition. Before using the recovery machine, check that it is in satisfactory working order, has been properly maintained and that any associated electrical components are sealed to prevent ignition in the event of a refrigerant release. Consult manufacturer if in doubt.
  - The recovered refrigerant shall be returned to the refrigerant supplier in the correct recovery cylinder, and the relevant Waste Transfer Note arranged. Do not mix refrigerants in recovery units and especially not in cylinders. If compressors or compressor oils are to be removed, ensure that they have been evacuated to an acceptable level to make certain that flammable refrigerant does not remain within the lubricant.
  - The evacuation process shall be carried out prior to returning the compressor to the suppliers. Only electric heating to the compressor body shall be employed to accelerate this process. When oil is drained from a system, it shall be carried out safely.

### Symbols Displayed on Unit

	Dangerous high voltage is present. Do not access a compartment with this symbol unless power is turned off.
	A pressurized liquid or gas is present. Do not puncture or heat up with a flame.
	A flammable chemical or gas is present. Do not use open flames to cut or solder unless the gas has been evacuated.
	Indicates the User Manual should be read before performing an operation.
	Indicates the Install & Service Manual should be read before performing an operation.
	Grounding point.

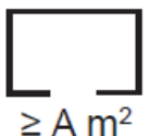

1. Amin is the required minimum room area (m<sup>2</sup>/ft<sup>2</sup>), as listed on the sticker near the nameplate.
2. Mrel is the maximum allowable refrigerant charge (kg/lb) that can be safely released in the space.

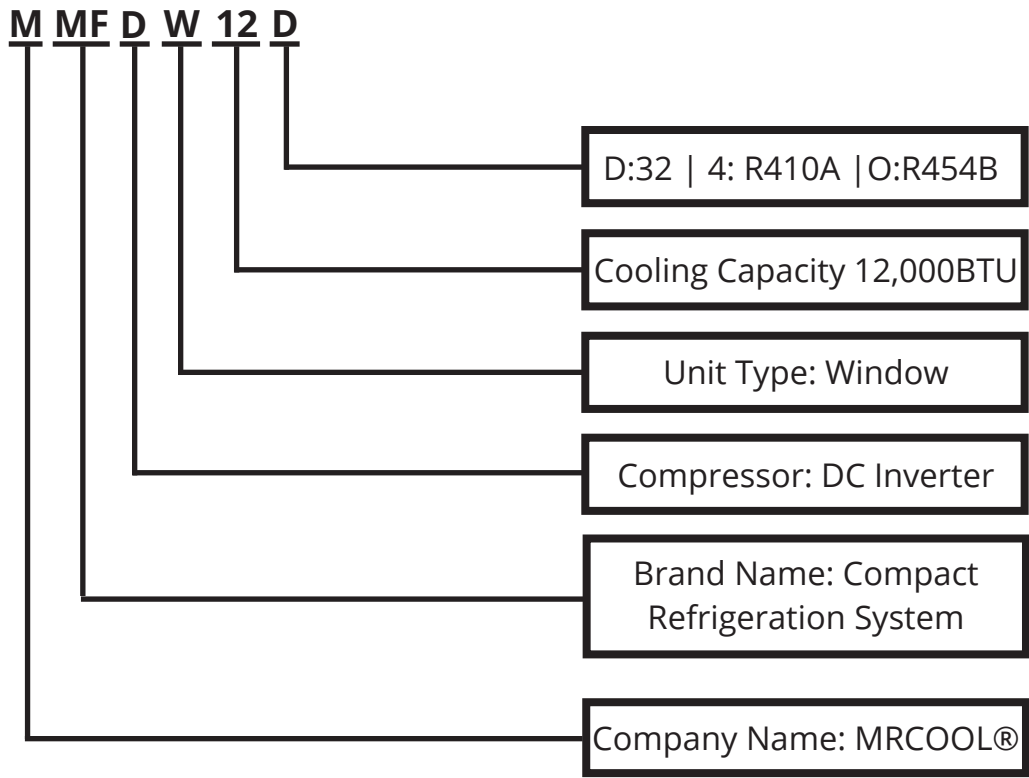

# 3 GENERAL DATA

Series Name		Unit	Compact Refrigeration System
Model		/	MEFDW12D
Prime Power Supply		VAC-Ph-Hz	208/230-1-50(60)
Auxiliary Power Supply		VDC	200/420
Cross-Sectional Area of Power Cable Conductor		mm <sup>2</sup>	2.5
Recommended Power Cable (Core)		/	3
MCA-Min. Current Ampacity		A	14.9
MOP-Max. Overcurrent Protection		A	25
Cooling Capacity@95/25°F (Ambient Temp./ Evaporating Temp.)		W	3,400
		Btu/h	12,000
Cooling Power Input		W	1,789
COP		W/W	1.9
Cooling Current		A	7.78
AWEF (Medium-Temp.)		/	8.2
Refrigerant		/	R32
Application Volume		ft <sup>3</sup> /m <sup>3</sup>	≤706.3/20
Compressor	Compressor Type	/	EVI DC Inverter Rotary
	Oil	/	POE VG75R
	Power	/	1,650
Condenser Fan	Fan Type	/	Axial-Flow
	Air Flow Volume	CFM	942
	Fan Motor Power	W	40
Evaporator Fan	Fan Type	/	Variable-Speed Centrifugal Fan
	Air Flow Volume	CFM	1,050
	Max. External Static Pressure	In.W.C./Pa	0.2/50
	Fan Motor Power	W	236
Cooling Throttling Method		/	EEV
Ambient Temperature Range		°F/°C	5~113/-15~45
Cold Storage Temperature Range		°F/°C	-0.4~50/-18~10
Max. Noise Level at 3.28ft. (1m.) Away	External Side	dB (A)	76
	Internal Side	dB (A)	66
Dimension (WxDxH)		in	28.15 x 38.58 x 21.65
		mm	715 x 980 x 550
Dimension of Package (WxDxH, with pallet)		in	30.12 x 39.37 x 28.54
		mm	765 x 1000 x 725
Net Weight		lbs/kg	180/82
Gross Weight		lbs/kg	231/102
Defrosting Method		/	Hot Gas Defrost
IP Class		/	IPX4

## 4.1 Error Codes

Fault Codes are displayed on the wired controller of the compact refrigeration system, and their respective troubleshooting methods are mentioned in this section.

### Indoor Ambient Temperature Sensor Fault (E0):

This fault code indicates a fault in the indoor ambient temperature sensor.

Possible Reason	Unit Status	Component to Check	Recommended Action
The sensor connection is loose	Unit will keep working	T3 Sensor	Check and correct the T3 connection with the integrated drive and control board.
The sensor is damaged			Unplug the T3 from the integrated drive and control board. Replace the T3 sensor.

### Defrost Temperature Sensor Fault (E1):

This fault code indicates a fault in the defrost temperature sensor.

Possible Reason	Unit Status	Component to Check	Recommended Action
The sensor connection is loose	Unit will keep working	T9 Sensor	Check and correct the T9 connection with the integrated drive and control board.
The sensor is damaged			Unplug the T9 from the integrated drive and control board. Replace the T9 sensor.

### Outdoor Ambient Temperature Sensor Fault (E2):

This fault code indicates a fault in the outdoor ambient temperature sensor.

Possible Reason	Unit Status	Component to Check	Recommended Action
The sensor connection is loose	Unit will keep working	T1 Sensor	Check and correct the T1 connection with the integrated drive and control board.
The sensor is damaged			Unplug the T1 from the integrated drive and control board. Replace the T1 sensor.

### Condenser Outlet Temperature Sensor (E3):

This fault code indicates a fault in the condenser exhaust temperature sensor.

Possible Reason	Unit Status	Component to Check	Recommended Action
The sensor connection is loose	Unit will keep working	T5 Sensor	Check and correct the T5 connection with the integrated drive and control board.
The sensor is damaged			Unplug the T5 from the integrated drive and control board. Replace the T5 sensor.

### Compressor Discharge Temperature Sensor Fault (E4):

This fault code indicates a fault in the compressor discharge temperature sensor.

Possible Reason	Unit Status	Component to Check	Recommended Action
The sensor connection is loose	Unit will keep working	T2 Sensor	Check and correct the T2 connection with the integrated drive and control board.
The sensor is damaged			Unplug the T2 from the integrated drive and control board. Replace the T2 sensor.

# 4 TROUBLESHOOTING

## Suction Temperature Sensor Fault (EP):

This fault code indicates a fault in the suction temperature sensor.

Possible Reason	Unit Status	Component to Check	Recommended Action
The sensor connection is loose	Unit will keep working	T4 Sensor	Check and correct the T4 connection with the integrated drive and control board.
The sensor is damaged			Unplug the T4 from the integrated drive and control board. Replace the T4 sensor.

## Supply Fan Fault (C2):

This fault code indicates a fault in the supply fan.

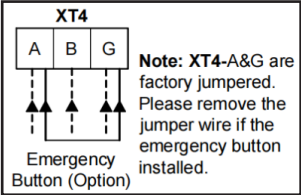
Possible Reason	Unit Status	Component to Check	Recommended Action
The supply fan is blocked by a foreign object	Unit will shut down	Supply Fan	<ol style="list-style-type: none"> <li>Power OFF the unit. Remove the evaporator fan housing. Rotate the evaporator fan blades manually to check for any noticeable resistance.</li> <li>If there is resistance, locate the foreign object obstructing the fan and remove it.</li> <li>Close the housing.</li> </ol>
The units supply voltage is too low		Power Supply	Measure the supply voltage using a multimeter. If voltage is below the allowable range specified on the nameplate and manual, the power supply must be replaced.
Auxiliary breaker switch is engaged		Auxiliary Breaker Switch	Rotate the button of the auxiliary breaker switch counter-clockwise until it pops out.
If the auxiliary breaker switch is not installed on the unit: Wires A and G on the XT4 are disconnected in the electrical box		Electrical Box; Wires	<ol style="list-style-type: none"> <li>Power OFF the unit and open the electrical junction box cover/terminal at the bottom right corner located on the front side of the unit.                              </li> <li>Check the status of the A &amp; G wires on XT4. Reconnect the wires on A and G if they are disconnected.                              </li> <li>Close the electrical junction box/terminal.</li> </ol>

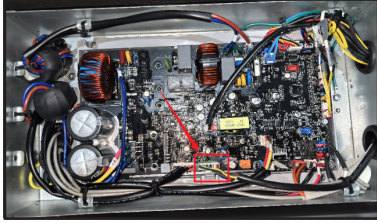
Fan is damaged	Unit will shut down	Evaporator Fan	<ol style="list-style-type: none"> <li>1. Power OFF the unit.</li> <li>2. Remove the evaporator housing.</li> <li>3. Disconnect the fan terminal DCFAN2 from the integrated drive and control board.</li> </ol>  <ol style="list-style-type: none"> <li>4. Remove the fan along with its mounting frame. Replace the fan.</li> <li>5. Reconnect the terminals/connectors.</li> <li>6. Reassemble the unit/housing.</li> </ol>
----------------	---------------------	----------------	--

### Wired Controller Communication Fault (C9):

This fault code indicates a communication disconnection between the wired controller and the unit.

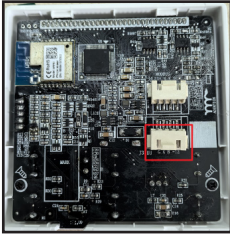
Possible Reason	Unit Status	Component to Check	Recommended Action
The wired controller connection is not using the standard communication cable		Communication Cable	<p>Replace the cable between the wired controller and the unit with the factory-supplied standard cable. Unplug both ends of the cable connected to the controller and replace it entirely.</p>
Wiring in the wired controller connection is incorrect	The wired controller is inoperable	Controller Connection Cable	<ol style="list-style-type: none"> <li>1. Power OFF the unit.</li> <li>2. Open the wired controller back panel by hand.</li> </ol>  <ol style="list-style-type: none"> <li>3. Reposition the wired controller connection to the location shown below.</li> </ol>  <ol style="list-style-type: none"> <li>4. Close the wired controller panel.</li> </ol>

# 4 TROUBLESHOOTING

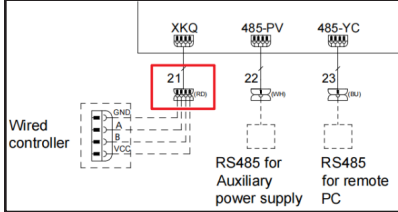
Wiring of the units connection is incorrect	The wired controller is inoperable	Wire Inside the Electrical Box	<ol style="list-style-type: none"> <li>1. Power OFF the unit and open the electrical junction box/terminal.</li> <li>2. Connect the unit's wiring to the adapter labeled as wire/connector number 21. Refer to the Installation Manual for more details.</li> </ol>  <ol style="list-style-type: none"> <li>3. Close the electrical junction box/terminal.</li> </ol>
---	------------------------------------	--------------------------------	--



## Enthalpy Enhancement Inlet Gas Temperature Sensor Fault (HA):

This fault code indicates a fault in the enthalpy enhancement inlet gas temperature sensor.

Possible Reason	Unit Status	Component to Check	Recommended Action
The sensor connection is loose	Unit will keep working	T6 Sensor	Check and correct the T6 connection with the integrated drive and control board.
The sensor is damaged			Unplug the T6 from the integrated drive and control board. Replace the T6 sensor.

## High Discharge Temperature Fault (H0):

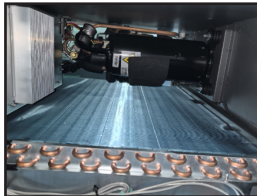
This fault code indicates that the system discharge temperature is too high during operation.

Possible Reason	Unit Status	Component to Check	Recommended Action
Inlet/outlet on the condenser side is blocked	Unit will shut down	Air Inlet and Outlet	<ol style="list-style-type: none"> <li>1. Power OFF the unit and remove the condenser housing.</li> <li>2. Inspect both sides of the condenser. Remove debris from the surface of the air intake fins on the condenser side.</li> </ol>  <ol style="list-style-type: none"> <li>3. Clean the condenser fan using a high-pressure water spray in the direction shown below:</li> </ol>  <ol style="list-style-type: none"> <li>4. Close the housing.</li> </ol>
The fan is not working		Condenser Fan	<ol style="list-style-type: none"> <li>1. Power OFF the unit for 3 minutes and then power ON again. The fault will clear automatically. Restart the unit and check whether the condenser fan operates normally.</li> <li>2. If the fan fails to start properly, refer to Condenser Fan Fault (L8) Section.</li> </ol>

## Low Pressure Fault (H5):

This fault code indicates that the units refrigerant is too low during operation.

Possible Reason	Unit Status	Component to Check	Recommended Action
The inlet/outlet on the evaporator side is blocked	Unit will shutdown	Air Inlet and Outlet	<ol style="list-style-type: none"> <li>Power OFF the unit and remove the evaporator housing.</li> <li>Remove debris from the evaporator's air inlet, outlet, and coil to ensure that the unit's airflow is unobstructed.                             <div data-bbox="1144 457 1425 751" data-label="Image"> </div> </li> <li>If there is severe icing on the evaporator coil, pour warm water over the coil or wait until the indoor temperature rises and the ice has completely melted before restarting the unit.</li> <li>Close the housing.</li> </ol>
The refrigerant is leaking		Piping	<ol style="list-style-type: none"> <li>Remove the condenser housing.</li> <li>Check the system pressure through the service valve. If the gauge reads 0, the system has a refrigerant leak.                             <div data-bbox="1161 1075 1409 1369" data-label="Image"> </div> </li> <li>Locate the leak in the piping, perform repairs, evacuate the system, and recharge refrigerant according to the nameplate.                             <p><b>NOTE:</b> Leak searching and brazing is to be performed by qualified personnel only. Non-qualified personnel must not work on refrigerant equipment.</p> </li> </ol>
Fan fault		Evaporator Fan	<ol style="list-style-type: none"> <li>Power OFF the unit for 3 minutes and then power ON again. The fault will clear automatically. Restart the unit and check whether the evaporator fan operates normally.</li> <li>If the evaporator fan does not start properly, refer to Supply Fan Fault (C2).</li> </ol>

# 4 TROUBLESHOOTING

## Enthalpy Enhancement Outlet Gas Temperature Sensor Fault (H9):

This fault code indicates a fault in the enthalpy enhancement outlet gas temperature sensor.

Possible Reason	Unit Status	Component to Check	Recommended Action
The sensor connection is loose	Unit will keep working	T7 Sensor	Check and correct the T7 connection with the integrated drive and control board.
The sensor is damaged			Unplug the T7 from the integrated drive and control board. Replace the T7 sensor.

## Condenser Fan Fault (L8):

This fault code indicates a condenser fan fault.

Possible Reason	Unit Status	Component to Check	Recommended Action
The fan is blocked by a foreign object	Unit will shut down	Condenser Fan	<ol style="list-style-type: none"> <li>1. Power OFF the unit. Remove the evaporator fan housing. Rotate the evaporator fan blades manually to check for any noticeable resistance.</li> <li>2. If resistance is detected, locate the foreign object obstructing the fan and remove it.</li> <li>3. Close the housing</li> </ol>
The main power supply voltage is too low		Power Supply	Measure the supply voltage using a multimeter. If the voltage is below the allowable range specified on the nameplate and manual, the power supply must be corrected.
The fan is damaged		Fan Motor	<ol style="list-style-type: none"> <li>1. Power OFF the unit.</li> <li>2. Remove the condenser panel.</li> <li>3. Disconnect the fan terminal DCFAN1 from the integrated drive and control board.</li> <li>4. Dismount the fan motor from the fan mounting frame.</li> <li>5. Replace the fan motor.</li> <li>6. Reconnect the terminal and reassemble the unit.</li> </ol>

## Prime Power Lost (L9):

This fault code indicates a main power disconnection.

Possible Reason	Unit Status	Component to Check	Recommended Action
Main power is disconnected	Fault Report	Power Supply	Power OFF the unit. Use a multimeter to measure the unit's input voltage at the electrical junction box/terminal. If the reading is 0, it is confirmed that the main power is disconnected.
Cable is not connected		Power Supply Cable	<ol style="list-style-type: none"> <li>1. Power OFF the unit.</li> <li>2. Check whether the unit's power supply cable is properly connected.</li> </ol>  <ol style="list-style-type: none"> <li>3. Inspect and connect the power supply cable properly to restore power to the unit.</li> </ol>

## Drive (VFD) Fault (LU):

This fault code indicates a variable frequency drive malfunction. This fault is triggered if single/multiple faults occur 6 times or more within an hour. If a single type of fault occurs six times in one hour, or if the total number of faults exceed six within the same period, the system will enter a lockout mode and shut down the unit to prevent further faults.

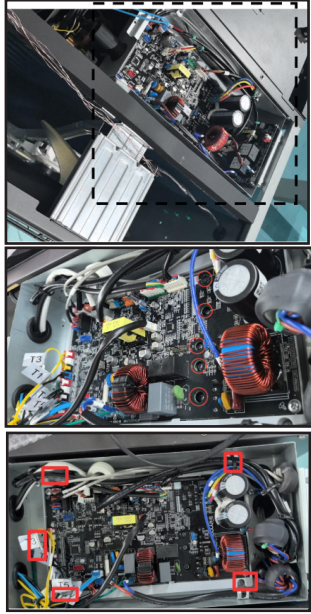
Possible Reason	Unit Status	Component to Check	Recommended Action
Integrated drive and control board is damaged	Unit will shut down	Integrated drive and control board	<ol style="list-style-type: none"> <li>Power OFF the unit for 3 minutes and restart it. The fault will clear automatically. Restart the unit and check whether the compressor starts normally. There is a noticeable starting sound and vibration when the compressor starts normally.</li> <li>If the compressor does not start properly, and a driver fault is reported after startup, the integrated drive and control board is damaged and must be replaced. <ul style="list-style-type: none"> <li>Remove the condenser housing. <ul style="list-style-type: none"> <li>Open the board housing.</li> <li>Mark all connectors and cables.</li> </ul> </li> <li>Disconnect all connectors and cables.</li> <li>Remove the 10 cross-head screws.  </li> <li>Replace the board.</li> <li>Install 10 cross-head screws. Tighten according to the wiring diagram.</li> <li>Install the condenser housing.</li> </ul> </li> </ol> <p><b>NOTE:</b> Cables/connectors must be installed according to the wiring diagram by qualified personnel. Incorrect installation may result in explosion and fire.</p>
Main power supply voltage is too low		Power Supply	<p>Measure the supply voltage using a multimeter. If the voltage is below the allowable range specified on the nameplate and manual, the power supply must be corrected.</p>

# 4 TROUBLESHOOTING

Main power supply voltage peak	Unit will shut down	Power Supply	The main power supply peak may trigger the IPM protection to induce the fault. Restart the unit to clear the fault.
Multiple failures		-	<ol style="list-style-type: none"> <li>1. Power OFF and restart the unit.</li> <li>2. If the unit does not restore after a system restart, contact support.</li> </ol>

## Four-way Valve Fault (D5):

This fault code indicates a four-way valve malfunction.

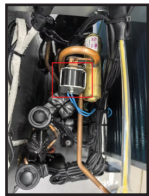
Possible Reason	Unit Status	Component to Check	Recommended Action
Four-way valve coil is loose	Unit will shut down	Four-Way Valve Coil	Check whether the four-way valve coil is loose and whether the coil terminals (CN1) are properly connected to the integrated drive and control board.
Four-way valve coil is damaged			<p>Power OFF to clear the fault, then restart the unit. If the four-way valve still fails to switch during defrost and the fault is reported again on the wired controller, the four-way valve coil needs to be replaced.</p> <p>Remove the condenser housing to access the coil. Access the coil as shown below.</p> 
Four-way valve is blocked		Four-Way Valve	If the fault persists after replacing the four-way valve coil, the four-way valve may be blocked. Recover the refrigerant from the unit, replace the four-way valve, vacuum, then recharge the refrigerant according to the nameplate specifications.

## Auxiliary Breaker Fault (A5):

This fault code indicates that the auxiliary breaker switch is activated (open).

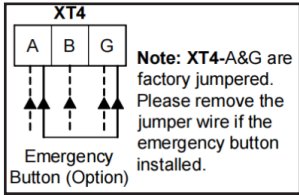
Possible Reason	Unit Status	Component to Check	Recommended Action
Auxiliary breaker switch is engaged	Unit will shut down	Auxiliary Breaker Switch	<p>Rotate the button of the auxiliary breaker switch counter-clockwise until it pops out.</p>
<p>If the Auxiliary breaker switch is not installed on the unit: Wires A and G on XT4 are disconnected in the electrical box.</p>		Electrical Junction Box/ Terminal; Wires	<p>1. Power OFF the unit and open the electrical junction box cover/terminal at the bottom right corner located on the front side of the unit.</p>  <p>2. Check the status of the A&amp;G wires on XT4. Reconnect the wires A and G if they are disconnected:</p>  <p>3. Close the electrical junction box/terminal.</p>
Auxiliary breaker switch is damaged		Auxiliary Breaker Switch	<p>If the fault persists after ruling out the above procedures, the auxiliary breaker switch may be damaged. Replace the switch following the wiring diagram in the manual.</p>

# 4 TROUBLESHOOTING

## Low Pressure Sensor Fault (db):

This fault code indicates a fault in the low pressure sensor.

Possible Reason	Unit Status	Component to Check	Recommended Action												
Ambient temperature is too high exceeding 113°F (45°C)		-	Restart the unit after the indoor temperature drops below 104°F (40°C). The fault will then be cleared and the unit will operate normally.												
Low pressure sensor is damaged	Unit will keep working	Low-Pressure Sensor	<ol style="list-style-type: none"> <li>Power ON the unit.</li> <li>Remove the condenser housing. <ul style="list-style-type: none"> <li>Open the integrated drive and control board housing.</li> <li>Mark the connectors and cables involved in the process.</li> </ul> </li> <li>Remove the sensor connector P1 from the integrated drive and control board.</li> <li>Use a voltmeter to measure output voltage of the low pressure sensor between the blue and black wires at terminal P1 on the integrated drive and control board. Do not remove the connector during measurement. <div data-bbox="1209 856 1356 1003" data-label="Image"> </div> <p>If the reading is 5V or 0V, the low pressure sensor LP is faulty.</p> <p><b>NOTE:</b> Extra precautions must be taken when performing live measurements.</p> <div data-bbox="1117 1144 1437 1333" data-label="Diagram"> <table border="1"> <thead> <tr> <th>S. No</th> <th>Color</th> <th>Signal</th> </tr> </thead> <tbody> <tr> <td>1</td> <td>Red</td> <td>+5V</td> </tr> <tr> <td>2</td> <td>Blue</td> <td>Output Voltage</td> </tr> <tr> <td>3</td> <td>Black</td> <td>Ground</td> </tr> </tbody> </table> </div> </li> </ol> <ol style="list-style-type: none"> <li>Disconnect the connector P1 from the terminal on the board.</li> <li>Evacuate the refrigerant from the unit.</li> <li>Unswear and remove the damaged sensor LP.</li> <li>Recharge the unit.</li> </ol> <p><b>NOTE:</b> Refrigerant recharge is required to be handled by qualified personnel only.</p> <ol style="list-style-type: none"> <li>Reconnect the wiring and install the connector P1.</li> <li>Install the condenser housing.</li> </ol> <p><b>NOTE:</b> Cables/connectors must be installed according to the wiring diagram by qualified personnel. Incorrect installation may result in explosion and fire.</p>	S. No	Color	Signal	1	Red	+5V	2	Blue	Output Voltage	3	Black	Ground
S. No	Color	Signal													
1	Red	+5V													
2	Blue	Output Voltage													
3	Black	Ground													

## Indoor Temperature Fault (En):

This fault code indicates that the temperature of the cold storage box is abnormal.

Possible Reason	Unit Status	Component to Check	Recommended Action
Excess frost is accumulated and the unit is operating under resonance conditions	Unit will keep working	-	<p>Frost accumulation occurs causing restricted airflow and leading the unit to operate under resonance conditions.</p> <p>When the door is opened, humid air enters the system from the return supply side. If the door is not closed tightly, air leakage occurs, allowing moisture to enter continuously.</p> <ol style="list-style-type: none"> <li>Power the unit OFF.</li> <li>Clean/scrape off the ice from the unit.</li> <li>Activate the defrost function if any ice remains after manual removal/cleaning.</li> </ol> <p><b>Recommendation:</b> To avoid ice buildup, ensure that the door of the storage room is properly sealed and there are no air leaks.</p>

## 4.2 Uncoded Errors

These faults are not displayed on the Wired Controller of the unit. The faults and their troubleshooting methods are mentioned in the following parts.

### Electrical Faults:

This fault code indicates that the temperature of the cold storage box is abnormal.

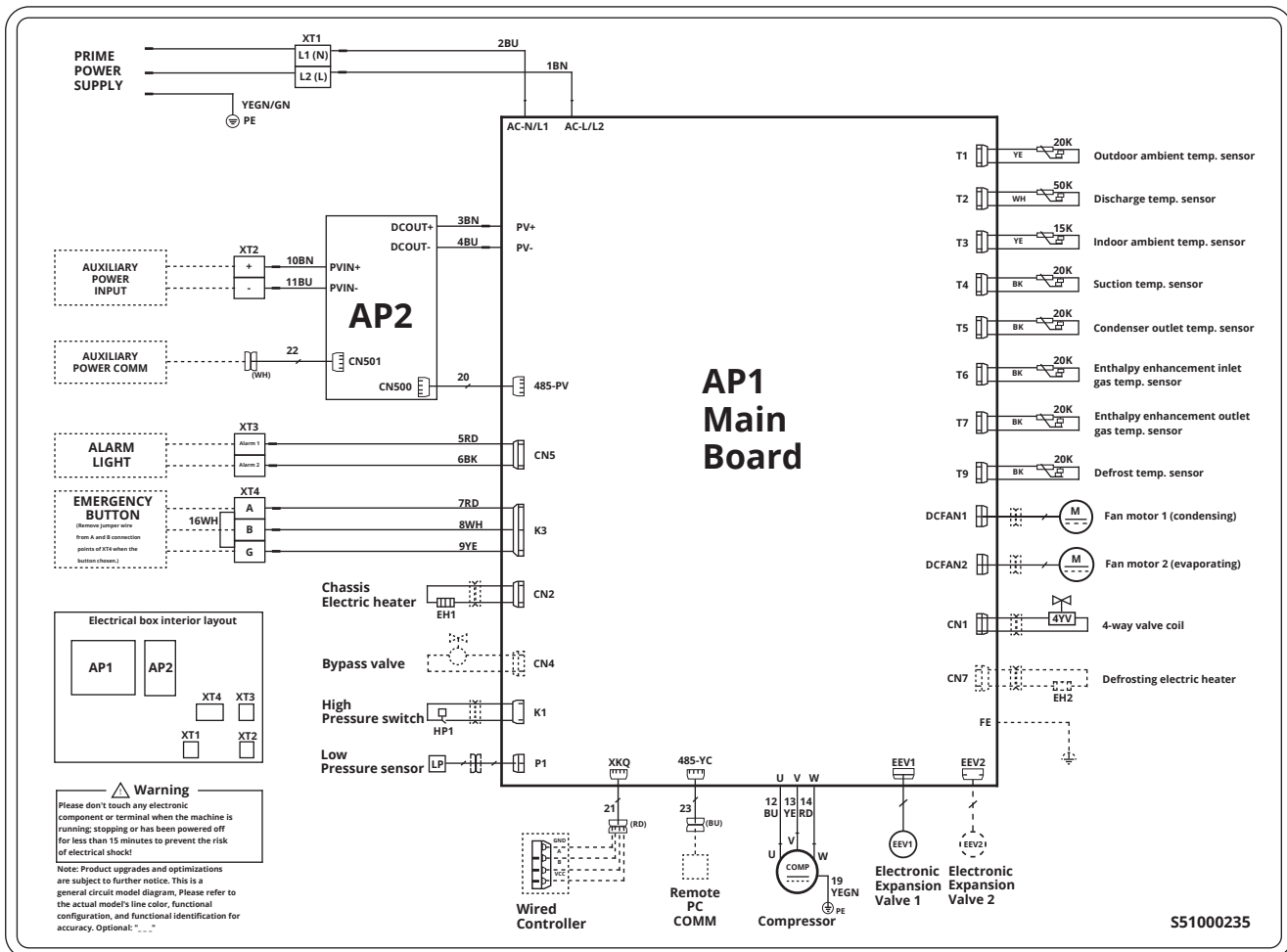

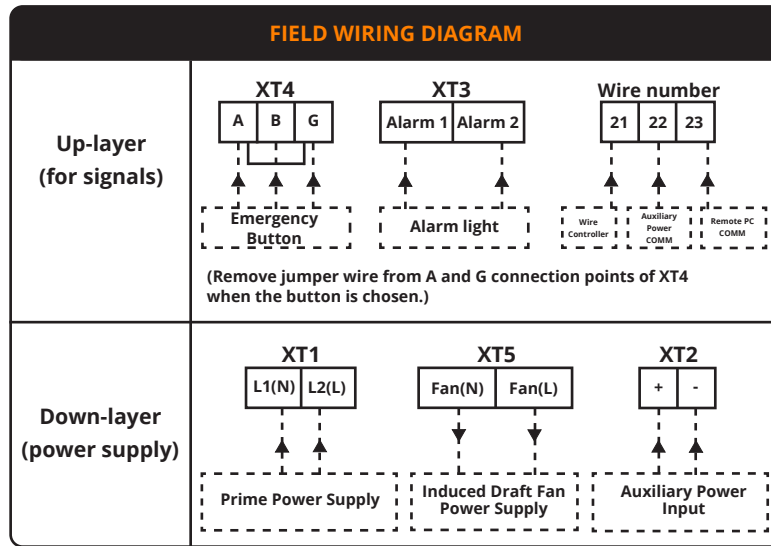

# 4 TROUBLESHOOTING

The wiring diagram of the electrical box is given below for reference:



The electrical faults which do not show any indication on the wired controller are mentioned below along with troubleshooting methods:

Fault	Unit Status	Component to Check	Recommended Action
Power supply		Power Supply Source	<ol style="list-style-type: none"> <li>1. Inspect the power supply cable to ensure it is in good condition with no surface damage to the wiring harness, and verify that both ends are securely connected.</li> <li>2. Use a multimeter to measure the supply voltage. If the measured voltage is outside the range specified on the nameplate, investigate and rectify the power supply abnormality.</li> </ol>
Wired Controller Connection	Wired controller is not responding	-	<ol style="list-style-type: none"> <li>1. Replace the connection cable between the Wired Controller and the unit with the standard communication cable supplied with the unit, and ensure that the cable is intact.</li> <li>2. Verify that both ends of the cable are connected.</li> <li>3. Power OFF the unit.</li> <li>4. Open the Wired Controller back panel by hand.</li> </ol> <div style="text-align: center; margin: 5px 0;">  </div> <ol style="list-style-type: none"> <li>5. Reposition the wired controller connection to the location shown below.</li> </ol> <div style="text-align: center; margin: 5px 0;">  </div> <ol style="list-style-type: none"> <li>6. Close the wired controller panel.</li> <li>7. Open the electrical junction box/ terminal.</li> </ol>

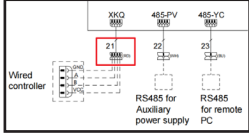
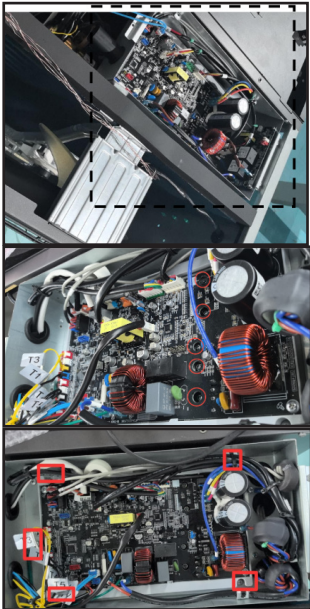
<p>Wired Controller Connection</p>		<p>-</p>	<p>8. Connect the unit's wiring to the adapter labeled as wire/connector number 21. Refer to the installation manual for more details.</p>  <p>9. Close the electrical junction box/terminal.</p>
<p>Integrated Drive and Control Board Overload</p>		<p>Integrated Drive and Control Board; Unit</p>	<ol style="list-style-type: none"> <li>1. If the power supply is confirmed to be normal and the integrated drive and control board fuse is intact, but the integrated drive and control board shows no flashing or indicator LED, it is likely that another component has overloaded and triggered the integrated board overload protection.</li> <li>2. In this case, allow the system to remain powered OFF for 30 minutes before powering up again.</li> </ol>
<p>Integrated Drive and Control Board Failure</p>	<p>Wired controller is not responding</p>	<p>Integrated Drive and Control Board</p>	<p>If the units power supply is confirmed to be normal and the integrated drive and control board overload protection has been ruled out, but the integrated drive and control board shows no flashing or indicator LED after powering ON, then the integrated drive and control board is damaged and must be replaced.</p> <ul style="list-style-type: none"> <li>• Remove the condenser housing.</li> <li>• Open the integrated drive and control board housing.</li> <li>• Mark all connectors and cables.</li> <li>• Disconnect all connectors and cables</li> <li>• Remove the 10 cross-head screws from the board.</li> </ul> 

# 5 MAINTENANCE

Integrated drive and control board failure	Wired Controller is not responding	Integrated Drive and Control Board	<ul style="list-style-type: none"> <li>Replace the board.</li> <li>Install the 10 cross-head screws. Tighten then diagonally.</li> <li>Connect all the cables and connectors strictly according to the wiring diagram. <ul style="list-style-type: none"> <li>Install the condenser housing.</li> </ul> </li> </ul> <p><b>NOTE:</b> Cables and connectors must be installed strictly according to the wiring diagram and only by qualified personnel. Incorrect installation may result in explosion and fire.</p>
Wired Controller Failure		Wired Controller	After confirming that the power supply is normal, the wiring of the wired controller is correct, and the integrated drive and control board is functioning properly, if the wired controller still does not display, it is faulty and must be replaced.

## 5.1 Evaporator Fan

### Tools Required:

#	Name	Size	Quantity
1	Phillips Screwdriver	PH#3	1
2	Phillips Screwdriver	PH#2	1
3	Phillips Screwdriver	PH#1	1
4	Phillips Screwdriver	PH#0	1
5	Ziploc Bag	-	As Needed

### Removal of Evaporator Housing & Fan:

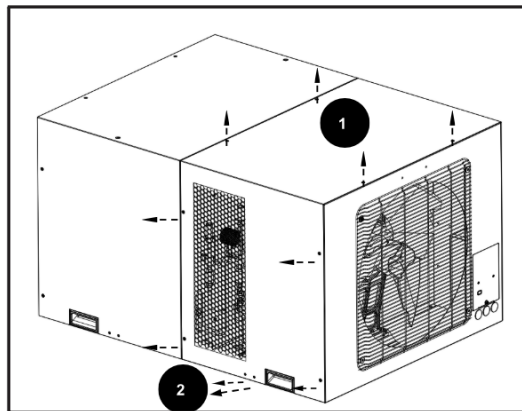

- Power OFF the unit and disconnect all wiring.
- Place the unit on a horizontal surface.
- Remove the 12 x M4 x 12① screws and the 4 x M6 x 12② (shown in the image above) screws from the housing of the condenser fan.
- Remove the metal housing and keep it in a safe area. Keep the screws in a safe area so you do not lose them.

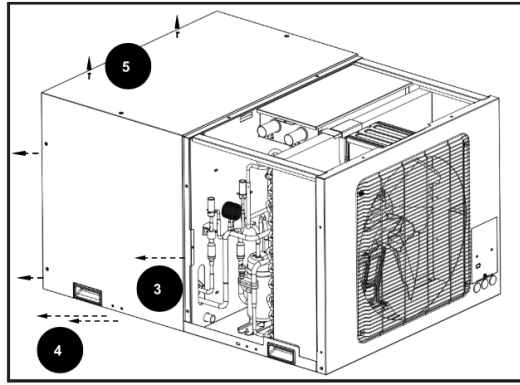

5. Remove the 2 x 4.2mm. self-tapping screws③, 4 x M4 x 12 stainless steel screws④, and the 6 x M4 x 12 special black flat countersunk head screws⑤from the housing of the evaporator fan. Remove the metal housing and screws and place in a safe place.

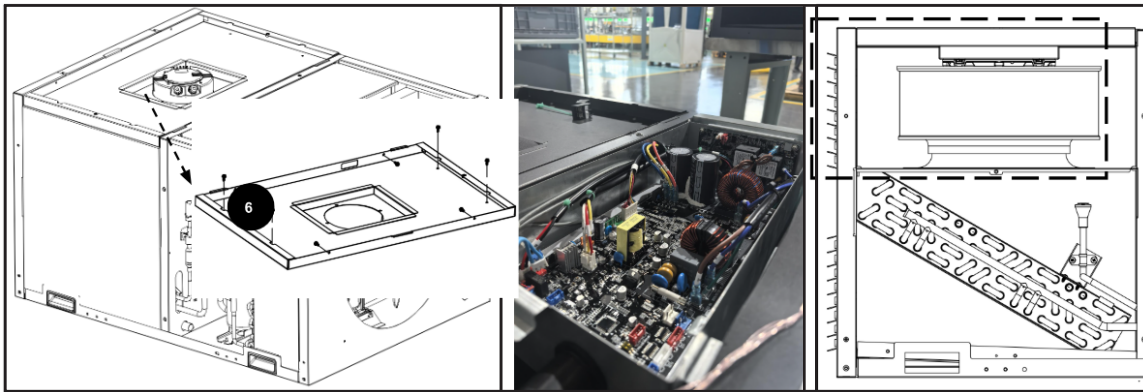

6. Disconnect the evaporator fan connector DCFAN2 from the integrated drive and control board. Remove the 8 x 4.2mm. self-tapping screws⑥. Remove the fan frame mounting sheet. Keep the screws in a safe area.

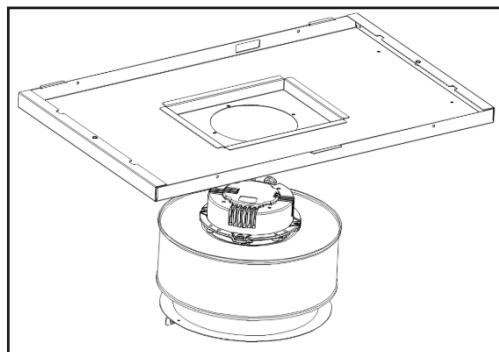
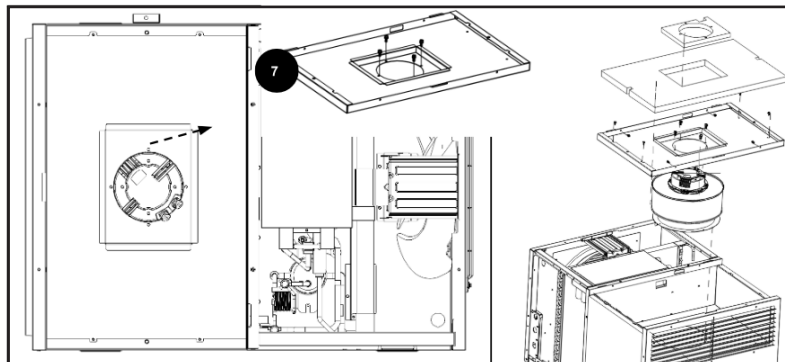

7. Remove the 4 x M6 x 16 screws⑦. Remove the evaporator fan and screws and place in a safe area.

## Installation of Evaporator Housing & Fan:

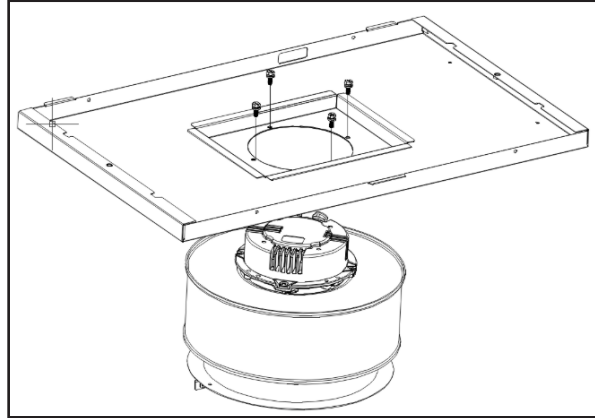

1. Place the fan vertically on the mounting frame with the motor/shaft end facing up. Install the 4 x M6 x 16 screws diagonally at their respective positions, then tighten the screws.

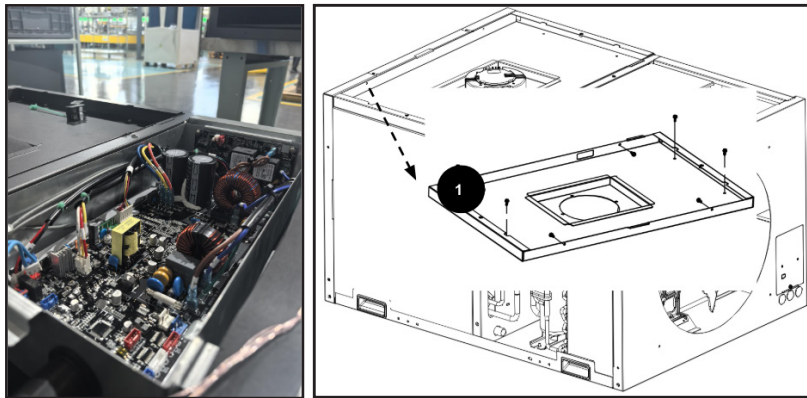

2. Connect the evaporator fan connector DCFAN2 with the integrated drive and control board. Install the fan frame mounting sheet. Install the 8 x 4.2mm. self-tapping screws ① at their respective positions, then tighten the screws.

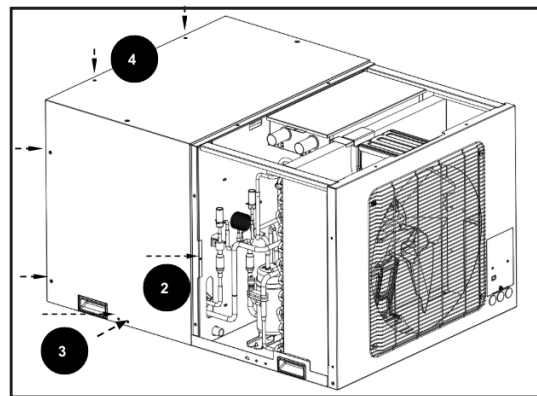

3. Install the metal housing of the evaporator fan. Install 2 x 4.2mm. self-tapping screws ②, 4 x M4 x 12 stainless screws ③ and 6 x M4 x 12 special black plate countersunk screws ④ at their respective positions, then tighten the screws.

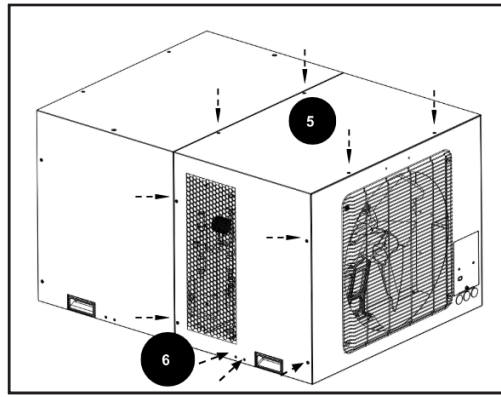

4. Install the metal housing of the condenser fan at its position. Install the 12 x M4 x 12<sup>⑤</sup>screws and 4 x M6 x 12 screws at their respective positions, then tighten the screws.

## 5.2 Condenser Fan

### Tools Required:

#	Name	Size	Quantity
1	Phillips Screwdriver	PH#2	1
2	Phillips Screwdriver	PH#1	1
3	Spanner/wrench	10mm.	1
4	Ziploc Bag	-	As Needed

### Removal of Condenser Housing & Fan:

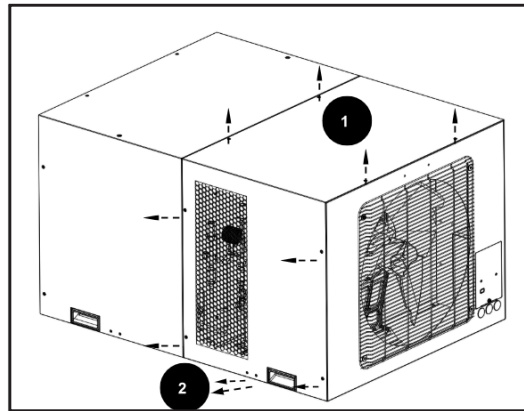

1. Power OFF the unit and disconnect all wiring.
2. Place the unit on a horizontal surface.
3. Remove the 12 x M4 x 12<sup>①</sup>screws and the 4 x M6 x 12<sup>②</sup>screws from the housing of the condenser fan.
4. Remove the metal housing and keep it in a safe area. Keep the screws in a safe area so you do not lose them.

# 5 MAINTENANCE

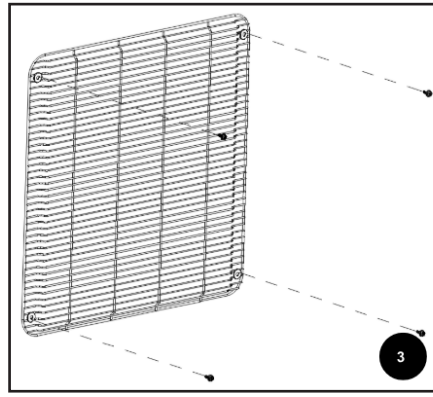
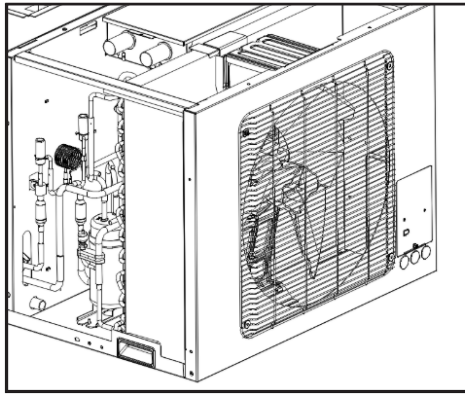

4. Remove the 4 x 4.2mm. self-tapping screws③from the condenser fan grille. Remove the grille and screws and place in a safe area.

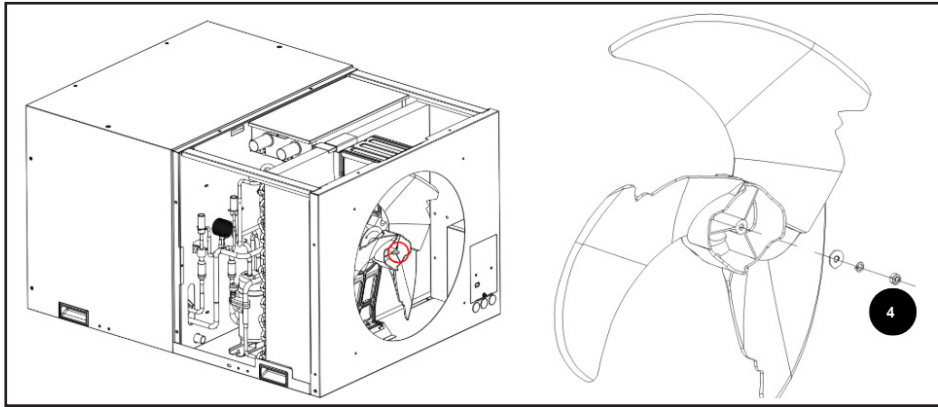

5. Remove the M5 x 5.2 lock nut④, lock washer, and flat washer from the condenser fan. Remove the condenser fan, lock nut, flat washer, and lock washer in a safe area.

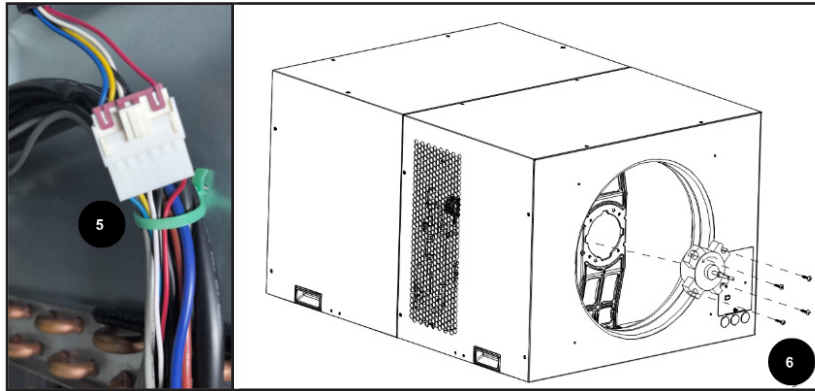

6. Disconnect the connector⑤located along the lead wire of the condenser fan. Remove the 4 x 4.8mm. self-tapping screws⑥from the condenser fan motor. Remove the condenser fan motor from the mounting frame and keep the fan motor and screws in a safe area.

## Installation of Condenser Housing & Fan:

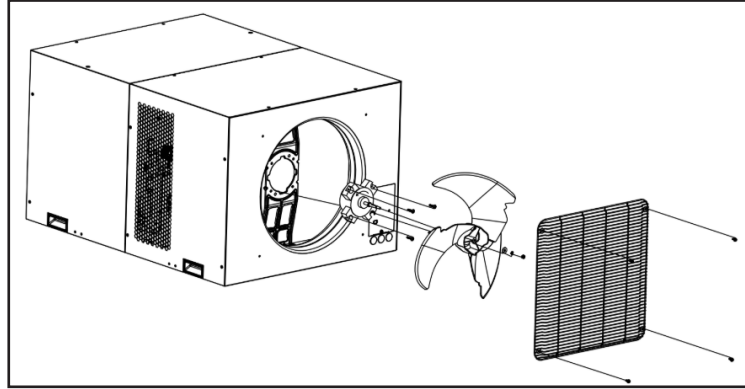

1. Install the motor horizontally on the mounting frame with the motor shaft facing outward.

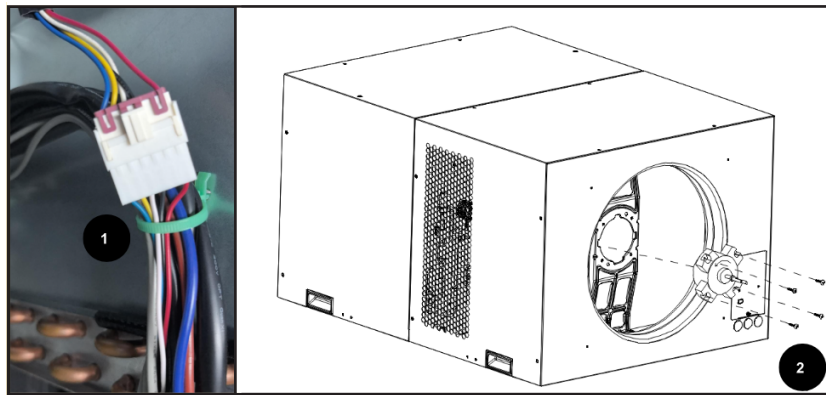

2. Connect the connector ① located along the lead wire of the condenser fan. Install the 4 x 4.8mm. self-tapping screws ② diagonally at their respective positions, then tighten the screws.

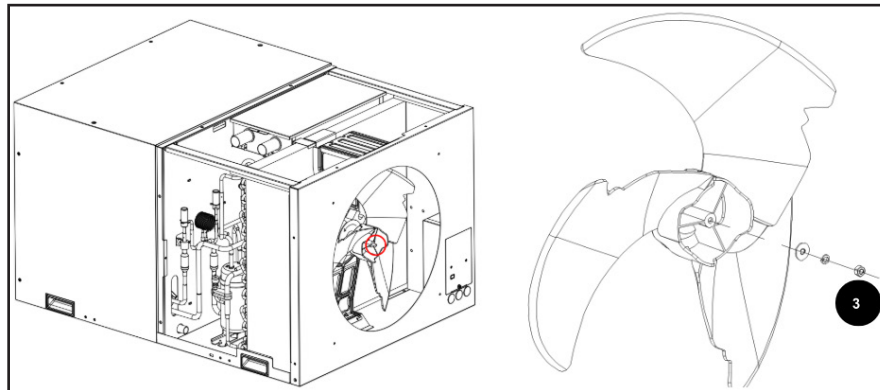

3. Install the condenser fan on the motor shaft. Apply a layer of thread-locker adhesive (low-medium strength thread-locker adhesive) to one-third of the threads where the lock nut will be installed. Install a flat washer, lock washer, and M5 x 5.2 lock nut ③ on the motor shaft and tighten.

# 5 MAINTENANCE

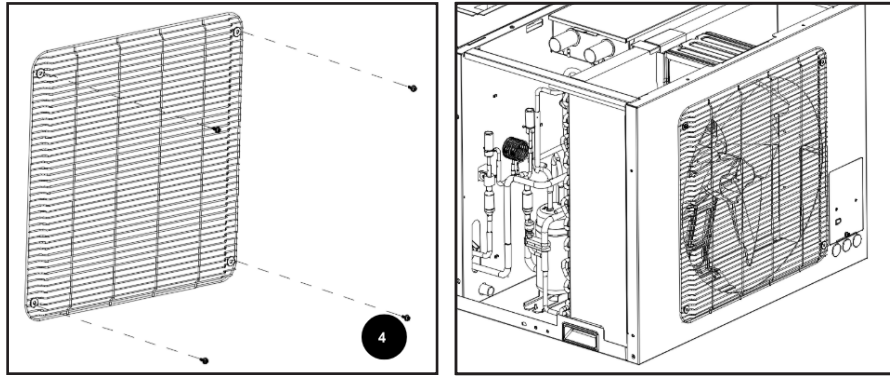

4. Install the grille in the correct position, then install the 4 x 4.2mm. self-tapping screws (4) at their respective positions, then tighten the screws.

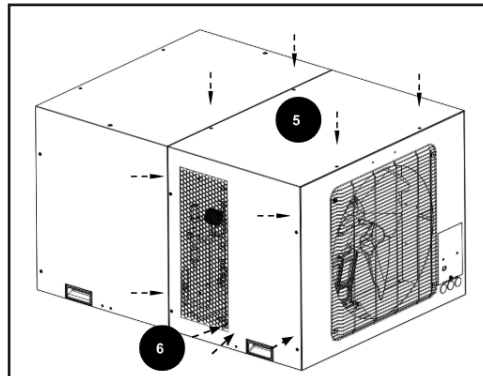

5. Install the metal housing of the condenser fan in its position. Install the 12 x M4 x 12 (5) screws and the 4 x M6 x 12 (6) screws at their respective positions, then tighten the screws.

## 5.3 Temperature Sensors

### Tools Required:

#	Name	Size	Quantity
1	Phillips Screwdriver	PH#1	1

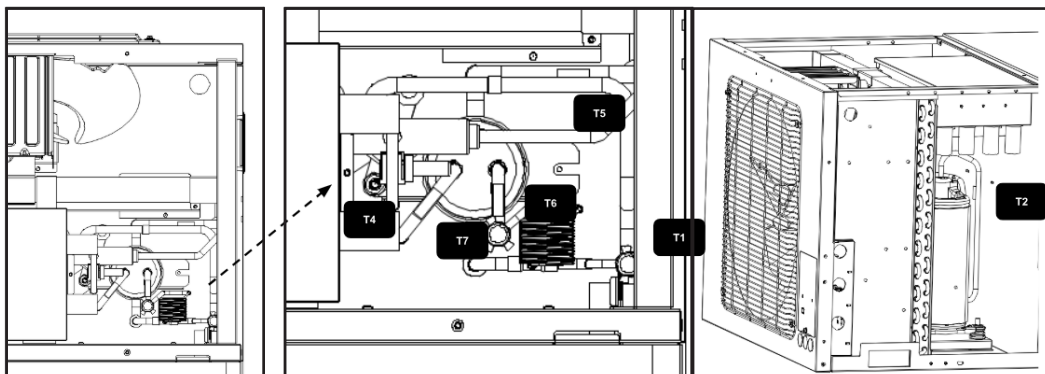

1. Sensors T1, T2, T4, T5, T6, and T7 can be accessed after removing the condenser housing.

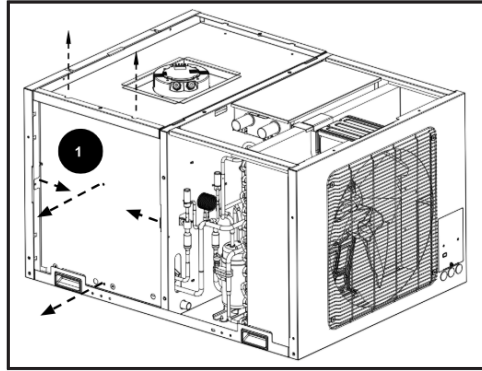

2. Sensors T3 and T9 can be accessed after removing the panel on the right side of the evaporator section of the unit. Remove the housing of the evaporator to access the panel on the right side. Remove 6 x 4.2mm self-tapping screws ① from the panel to access T3 and T9.

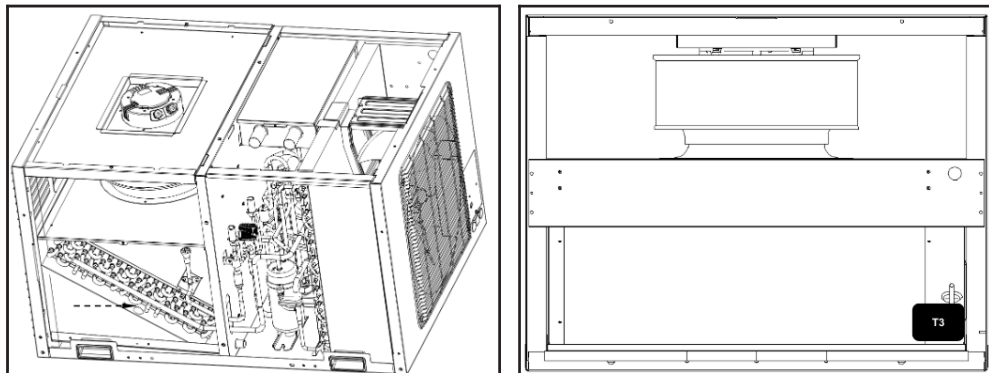
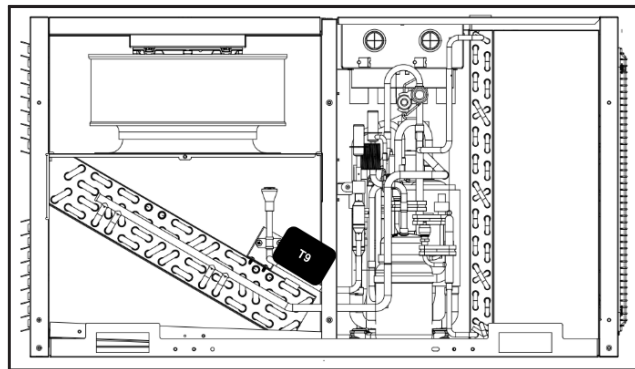

3. T9 is fixed on the evaporator U-tube. T3 is secured inside the indoor air inlet with a branch cable tie. T3 passes through the cable grommet or ring next to the evaporator bracket.



**MRCOOL®**  
COMFORT MADE SIMPLE

# **MRCOOL® COMPACT REFRIGERATION SYSTEM**

The design and specifications of this product and/or manual are subject to change without prior notice.  
Consult with the sales agency or manufacturer for details.